

C O O P E R

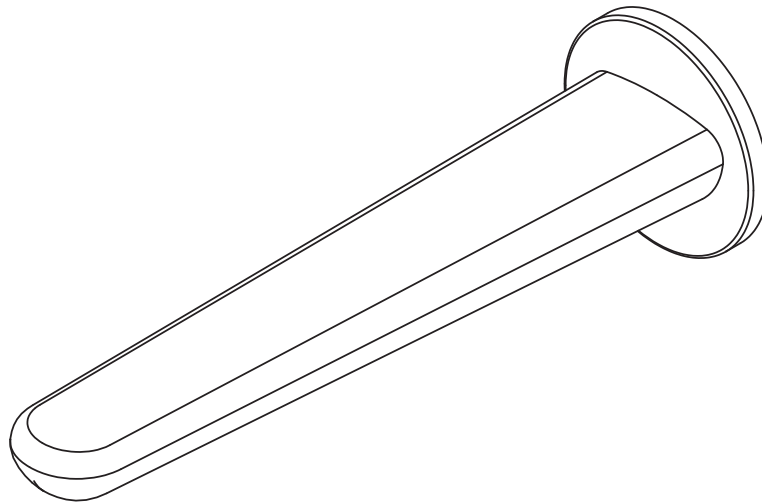

G R A H A M

INSTALLATION INSTRUCTIONS



EMILE WALL MOUNT TUB SPOUT

EMI-11000

DIMENSIONS In Inches & Millimetres

EMILE WALL MOUNT TUB SPOUT

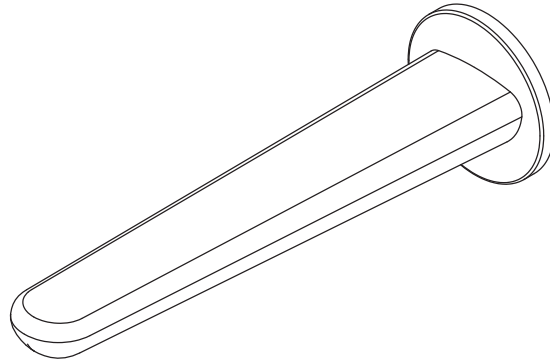

TOP VIEW

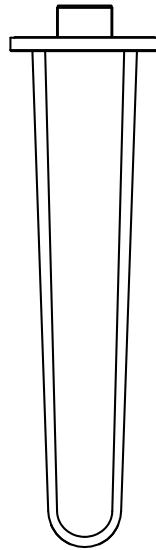

FRONT VIEW

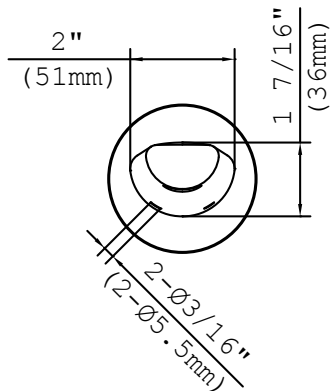

SIDE VIEW

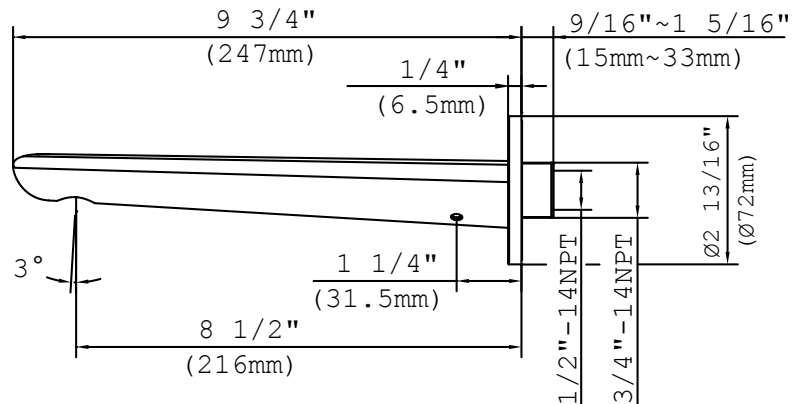

PRODUCT INFORMATION

TOOLS



Groove Joint Pliers



Adjustable Wrench

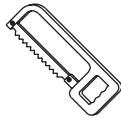

Hacksaw



Phillips Screwdriver

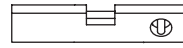

Level



Pipe Tape

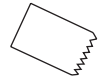

Spatula

MAINTENANCE

- Your new Cooper and Graham product is designed for years of trouble-free performance.
- Keep it looking new by cleaning it periodically with a soft cloth. Avoid abrasive cleaners, wire wool and harsh chemicals as these will dull the finish and void your warranty.

IMPORTANT POINTS

- Prior to beginning installation, turn off the cold and hot water lines. If applicable, open the existing valve to release built-up pressure.
- Overtightening nuts may cause damage.
- Wrap all threaded connections with pipe tape available at your local plumbing supply store. Always wrap in clockwise direction. The fittings should be installed by a state licensed plumber.
- Note: When there is a difference in water pressure between hot and cold supplies to the mixing valve, the pressures should be equalized by a plumber in accordance with best practice and legislation.
- Note: This product is designed to function as part of the water system at a supply pressure between 140 and 860 kPa (20 and 125 psi). The leakage test to the water system should be carried out using water as this product contains the components are specifically designed for water, for which the viscosity and surface tension are much greater comparing to air or gas, both of these are unique forces that resist the tendency of water to flow, particularly through a small opening, however at the same condition the air or gas might be able to escape through. In the exceptional circumstances should pneumatic pressure testing using compressed inert gas or air be used, the pressure should be equal or less than 3bar. Conducting the pneumatic pressure test at a higher pressure can be very hazardous not only to the person who does the test, but also to the product itself or the users. Due to the air or gas is very compressible, the same pressure of compressed air or gas contains much more energy than the liquid therefore should a joint, pipe, or any other component fail under test pressure when using compressed air or gas, the energy can be released with dangerous force to human or damaging the system.

SAFETY TIPS

- If you are soldering during faucet installation, remove cartridges, seats, gaskets and washers prior to applying flame, otherwise you will void the warranty.
- When cutting or soldering pipe, use safety glasses to protect your eyes.
- Cover drain openings to avoid losing small parts.

CODES/STANDARDS

- Certifications: IAPMO(cUPC)



Cooper and Graham always recommends that plumbing products be installed by a licensed professional.

1.

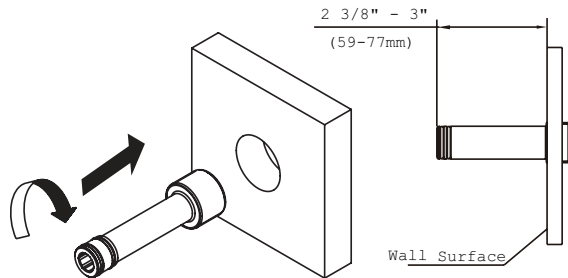

Install the fixing pipe to elbow located in the wall cavity. Make sure the fixing pipe protruding out of the wall surface is between $2 \frac{3}{8}'' \sim 3''$ (59mm ~ 77mm) after it is fixed.

2.

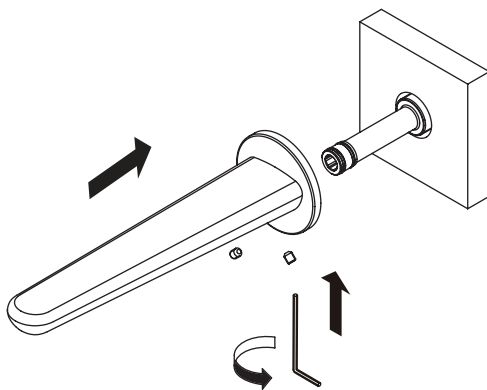

Install the spout to the fixing pipe and fix it with set screws.

3.

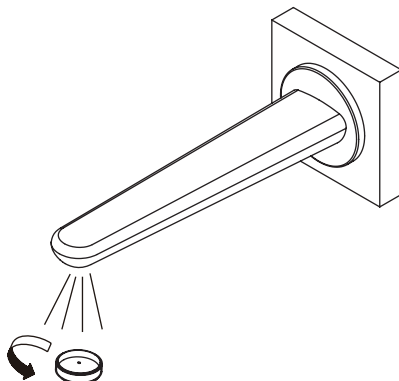

After installing faucet, remove the aerator and open the hot and cold supplies. Check for leaks. Turn on the faucet handle for one minute to flush debris from the faucet. Turn off the handle and re-assemble the aerator.

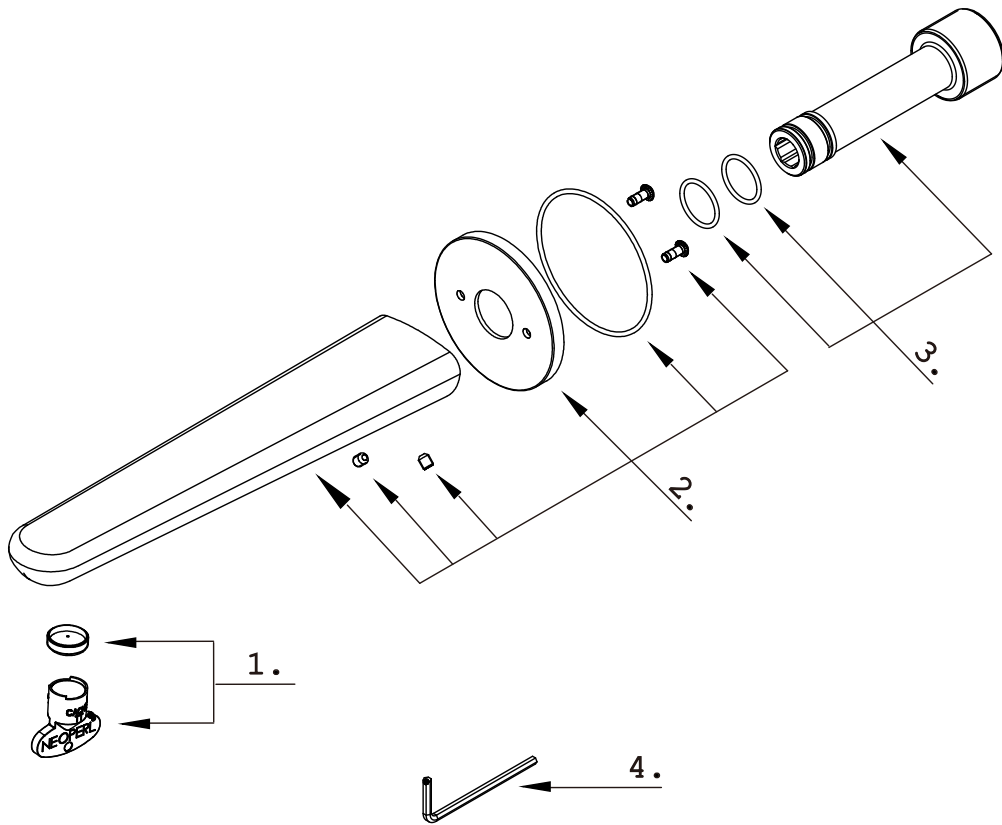

1. Aerator Assembly (A66G291)
2. Spout Assembly (A666A01)
3. Mounting Adaptor (A663A31)
4. Allen Key (H2.5 * 19mm * 53mm) (A031000)

C O O P E R



G R A H A M

FOR ADDITIONAL ASSISTANCE OR SERVICE CALL
T: 929.432.1699 F: 929.432.1833

CUSTOMERSERVICE@COOPERANDGRAHAM.COM
9AM-5PM EST, MONDAY - FRIDAY

COOPER AND GRAHAM

1828 TROUTMAN STREET, RIDGEWOOD, NY, 11385
WWW.COOPERANDGRAHAM.COM